

CUTTERBAR

HL 152, 182, 212 & 242



HANDBOOK

UK

1. edition 2020

GREENTEC

Cutting Edge Technology

Greentec HL 152,182,2121,242

Instruction manual 1. edition – 2020

Original edition

IMPORTANT

Make sure that the user is handed this instruction manual before using the machine for the first time. It is important that the user fully understands the content before using the machine.

In case of further resale of the machine, the instruction manual must be handed over to the new owner!

The content of the instruction manual is based on information that was valid at the time of publication.

As our products are under continuous development and improvement, changes in the specifications will be made. If there is information that differs from the machine at hand, you can receive instructions from the GreenTec Aftersale department.



Indholdsfortegnelse

PREFACE	5
Useful information	6
General information in the use of the instruction manual	7
Declaration of Conformity	9
SAFETY	10
Intended use	10
Unauthorized conversions and modifications are prohibited	10
Personnel qualification and training	10
General safety information	10
Safety information for operation	11
Safety information for assembly, maintenance and repair work	12
Personal safety equipment	13
Safety labels	14
DESCRIPTION	15
Overview of the cutterbar, type plate, warning plates and instruction plate	15
Layout and function	16
Technical data	17
ATTACHMENT AND REMOVAL	18
Delivery	19
Mounting	19
Start-up	21
Hedge trimming	23
Transport	24
Demounting	24
STORAGE AND MOVING THE MACHINE	25
Storage	25
Maintenance	26
Maintenance schedule	27
Cleaning	28
Parts replacement	29
Lubrication	43
Parts	43
TROUBLESHOOTING	45
BILAG 1	46
Tightening torques	46

Preface

Dear Customer!

Your new GreenTec machine is designed on the basis of more than 25 years of experience with tractor mounted machines for the maintenance of green areas. The machine is manufactured from the latest technology and in accordance with approved safety regulations, standards and requirements.

We want to provide a product where no damages or misunderstandings occur during operation, transport or maintenance of the machine.

The instruction manual contains information and instructions that are important and useful for maintaining the operational reliability and value of the GreenTec machine. Therefore, read this manual carefully as it will familiarize you with mounting, proper use, care and maintenance.

Pay special attention to safety instructions.

You are welcome to visit our website www.greentec.eu - where you can use the retailer login to access the latest updates of instruction manuals and spare parts catalogue for our whole product line.

We hope you will be pleased with your new GreenTec machine.

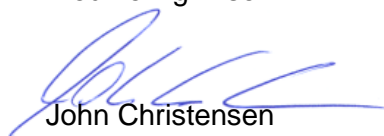

Med venlig hilsen

A blue ink signature of John Christensen, written in a cursive style.

John Christensen
Salgs Direktør GreenTec A/S

GreenTec's vision is to develop and sell quality machines for the maintenance of green areas, for example in agriculture, industry, airports and the municipal sector. Through innovative product development, we strive to become a leader in our field.

All machines are developed in a simple and functional design in close cooperation with retailers and end users. Our goal is to uncover all needs in the market segment, preferably with two different solutions. Through in-depth requirement analyzes and quality counselling, the customer is offered the best solution, where individual requirements can also be met through modular configuration of the product program. We also aims to offer the best possible after sales service and a fast and efficient spare parts supply.

Useful information

The first time the machine is used, the seller is responsible for giving the buyer this instruction manual. In addition, he must ensure that the buyer fully understands the content before proceeding. If the machine is resold, the instruction book **must** be handed over to the new owner.

The following fields are filled in for use when ordering spare parts or other inquiries.

Serial number

Date of delivery

Retailer

Mail

Phone



Merkurvej 25
DK 6000 Kolding
Danmark
Tel: +45 75553644
Fax: +45 75554243
Email: info@greentec.eu
web: www.greentec.eu
Åbningstid: mandag-fredag 8-16

General information in the use of the instruction manual

Read this instruction manual carefully before mounting and using a machine. If any doubts arise, contact your local retailer or the GreenTec Aftersale department. Only use original GreenTec spare parts on GreenTec machines and equipment.

Definitions:



The following definitions apply to this entire instruction manual:

⚠ DANGER!	
	<p>Direct danger to life and risk of injury! Directly dangerous situation that may lead to death or severe injuries.</p>
⚠ WARNING!	
	<p>Probable danger to life and risk of injury! Generally dangerous situation that may lead to death or</p>
⚠ CAUTION!	
	<p>Possible risk of injury! Dangerous situation that may lead to injuries.</p>
ATTENTION!	
	<p>Risk of damage to the device! Situation that may lead to property damage.</p>

Instruktion

Ved en instruktion gives oplysninger der bidrager til en bedre forståelse af betjeningen.

The following warning symbols are used in the warning notices:

-  General warning symbol
-  Warning of crushing injuries
-  Warning of cutting injuries

Left Hand (LH) & Right Hand (RH)

These terms are used when the machine is mounted on the vehicle seen from behind. The terms are also used when referring to the vehicle.

Serial number plate

All machines are equipped with a serial number plate that contains important information related to the machine, including a unique serial number used for identification.

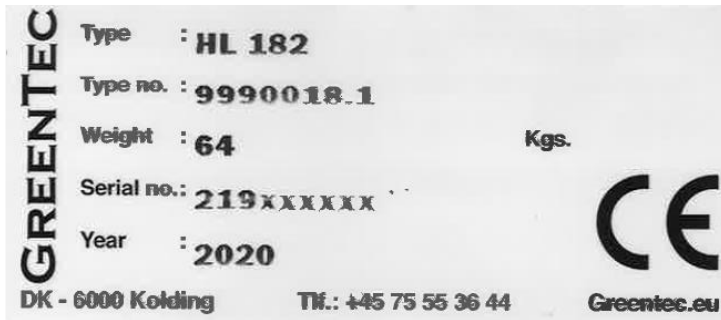

NOTICE

The symbols in this manual are for the sole purpose of instructing and informing and not illustrating the entirety of the components. Under special circumstances, the symbols may appear different from the current machine, when this occurs, the general procedure will be the same.

Declaration of Conformity

Iht.Maskindirektivet 2006/42/EF Bilag II.A

Manufactory: **GreenTec A/S**
 Address: **Mercurvej 25**
 Zip code and city: **DK-6000 Kolding**

I, the undersigned manufacturer, am authorized to prepare the technical documentation for the machine and on due request, provide the technical dossier.

Type	Produkt	Bemærkninger	Models
Tool	Cutterbar	Olieflow behov 20- 32 l/min	HL 152
		Olieflow behov 25- 40 l/min	HL 182
		Olieflow behov 25- 40 l/min	HL 212
		Olieflow behov 25- 40 l/min	HL 242
Hydraulic reach trimmer	Scorpion Serie 4 (Compact)	All HL- modeller can be mounted	330-4 S(backmount+ frontmount.) 430-4 S(backmount+ frontmount.)
	Scorpion Serie 6	All HL- modeller can be mounted	530-6 S(backmount+ frontmount.) 530-6 S Plus (backm. + frontm.) 630-6 S(bagmount + frontmount.) 630-6 S Plus (bagm. + frontm.)
	Scorpion Serie 8	All HL- modeller can be mounted	703-8 S (bagmount + frontmount.) 703-8 S Plus (bagm. + frontm.) 803-8 S (bagmount + frontmount.) 803-8 S Plus (bagm. + frontm.)
Tool frame	HXF 2302	Kun HL 152 can be mounted	HXF 2302 + HXF 2302 Tele
	HXF 2802	Alle HL- modeller can be mounted	HXF 2802 + HXF 2802 Tele
	HXF 3302	Alle HL- modeller can be mounted	HXF 3302 + HXF 3302 Tele

is manufactured by the above-mentioned company, complies with the guidelines of the European Parliament and the Directive of the European Council 2006/42 / EC, referring to international standards associated with its design and construction, as mentioned in the technical documents.

DS/EN ISO 12100 3rd edition 2011. Safety of Machinery – General principles for design – Risk assessment and risk reduction

DS/EN 14120 1th edition 2015. Safety of Machinery – Guards-General requirements for the design and construction of fixed and movable guards.

DS/EN ISO 4413 1th edition 2010. Hydraulic fluid power – General rules and safety requirements for systems and their components.

The declaration is valid for the tools mentioned above, including the machine's connections, i.e. suspension, stabilisation and hydraulic connection.

If the aforementioned equipment is connected to a vehicle with a tool frame or hydraulic reach trimmer other than those mentioned above, it is the user's responsibility to ensure that the vehicle and the machine as a whole meet the applicable requirements in the relevant directives for this.

Dato: 27.01.2020

Underskrift: 
John Christensen - Salgsdirektør

Safety

Intended use

The GreenTec hedge trimmer is designed for general hedge trimming within landscaping, gardening, agriculture, forestry or similar areas of application.

Trimming can be done vertically and horizontally.

The thickness of branches to be cut must not exceed 40 mm.

All inspection and maintenance work must be carried out promptly.

All usage that exceeds or deviates from this is considered to be non-compliance with the instruction book.

Non-compliance with the instruction book when using the hedge trimmer may cause personal injury and material damage.

The manufacturer accepts no liability for damage or injury that may arise as a result of the use of the hedge trimmer that does not comply with the instruction book.

Unauthorized conversions and modifications are prohibited

Do not make any unauthorized conversions or modifications to the hedge trimmer. Conversions or modifications are prohibited without the written permission of the manufacturer and exclude liability for resulting damages.

Personnel qualification and training

- The hedge trimmer may be used, maintained and repaired only by persons who are familiar with the system and have been instructed about the dangers.
- The area of responsibility, competence and supervision of personnel must be exactly defined by the operator.
- If the personnel do not have sufficient skills, they must be trained and instructed.
- The operator must ensure that personnel have read and understood the contents of this operating manual.
- Repairs that are not described in this operating manual may be carried out only by authorized repair shops.

General safety information

- The user must follow the safety instructions described here, and abide by the national regulations regarding general safety, and the responsibility for this rests with the owner/operations manager.
- The relevant safety regulations and the generally accepted rules on safety technology and occupational health, as well as the Road Traffic Act, must be complied with.
- The safety instructions of the manufacturer of the vehicle or tool carrier must be followed.
- At each start-up, the hedge trimmer must be checked for operational safety, for damaged and missing or worn parts. Any defects identified must be rectified promptly, before operation of the hedge trimmer begins.

- Safe operation of the hedge trimmer is only ensured if the blade is properly installed. Use suitable tools for the installation.
- The protective devices must be checked regularly, and damaged protective devices must be replaced.
- Only spare parts that are supplied by or have the explicit approval of the manufacturer must be used. The manufacturer accepts no liability and provides no guarantee in the event of damage or injury caused by the use of unoriginal parts.

Safety information for operation

- Familiarise yourself with all devices and operating components, as well as their function, before starting the work.
- Wear close-fitting clothes and use the necessary personal protective equipment.
- Check all mechanical and hydraulic connections and all installed safety devices for their functionality before using the machine.
- Check that the hydraulic hoses are correctly positioned. Hydraulic hoses that get caught up or crushed may cause personal injury (e.g. as a result of seeping hydraulic oil) or damage to the machine.
- Ensure all supporting devices are in the right position before mounting or demounting.
- Always place counter-weights on the mounting points provided for this purpose.
- Observe the limits for axle load, total weight and transport objective.
- Install and check the transport fittings such as lights and warning and protective devices.
- Install extra lighting if the lights fitted to the vehicle as standard are hidden by the equipment when it is in transport mode.
- Check the immediate surroundings for persons, especially children, and animals and obstructions before start-up and before you start driving. You must be sure that you have ample vision and a sufficient safety distance.
- The hedge trimmer's working area must be clear of persons when the engine is running.
- Other persons are not allowed to drive the hedge trimmer during operation or transport.
- Fold the hedge trimmer and the front or back-mounted expander on the vehicle together in transport mode.
- Before transport, you must secure the steering levers on the hedge trimmer in the vehicle against unintentional activation. Stop the PTO if it pulls the hydraulics.
- Never leave the driver's seat during transport.
- Adjust the speed to the current local road and traffic conditions. Avoid sudden changes of direction when travelling up or down hill and when travelling across an incline.
- Beware of the effects the mounted hedge trimmer and counter-weight have on the driving behaviour and the steering and braking ability.
- Only start the hedge trimmer up when all protective guards are demounted.

- Be particularly careful when working under high voltage cables. Keep a distance of at least 10 m from high voltage cables.
- If you run into an obstruction, you must stop the hedge trimmer immediately and check it for damage.
- Before getting down from the vehicle, you must place the hedge trimmer on the ground, remove the ignition key and secure the vehicle, to prevent it from rolling.
- The hedge trimmer may carry on running after it is switched off. Wait until it has stopped entirely.
- During work breaks you should place the hedge trimmer on the ground and install the Blade Guard and safety guards.
- With hydraulically activated parts there is a risk of body parts becoming crushed and unclipped.
- The hydraulic installation may be under pressure.
- Liquids (hydraulic oil) that are under great pressure and seep out may penetrate the skin and cause serious personal injury. In the event of personal injury, you should seek the help of a doctor immediately, as there is a risk of infection.
- Only connect hydraulic hoses when the hydraulic installation is free of pressure.
- Check the hydraulic hoses regularly for leakage, damage and ageing. Damaged hydraulic hoses must be replaced promptly. The new hydraulic hoses must meet the manufacturer's technical requirements.
- Oil leaks pose a hazard to the environment. Hydraulic oil seepage must be collected and disposed of in the proper manner.
- Use protective goggles when looking for leakages.

Safety information for assembly, maintenance and repair work

- Mounting, maintenance and repairs must be carried out exclusively by authorised and qualified specialists.
- Work on the machine may only be carried out when the machine is stationary. Always follow the procedure for stopping that is described in the manufacturer's instruction book.
- Wear close-fitting clothes and use the necessary personal protective equipment.
- If you have to carry out maintenance on the hedge trimmer while it is raised, it must be secured with a suitable support.
- Release the pressure in the hydraulic installation before starting any works on the hedge trimmer.
- Some of the hedge trimmer's parts may be very hot. Allow the hedge trimmer to cool off.
- Handle and dispose of oils and grease in accordance with the rules.
- All safety and protective devices must be installed or activated again immediately after a work session is finished.
- When starting up the machine again, you must follow the instruction book from the tool carrier or vehicle manufacturer.

Personal safety equipment

It is recommended that the following safety equipment be worn when working with or performing maintenance work on the machine.



Boiler suit



Safety boots



Safety goggles



Hearing
protection



Safety helmet



Safety work
gloves

The recommended safety equipment along with the special points of attention mentioned in the following sections cover the precautions GreenTec has considered necessary.

The varying circumstances that may arise during work with this machine can not always be foreseen. No good advice can replace "common sense" and "attention" at all times, but the above-mentioned is a good start for the safe use of your GreenTec machine.

Safety labels



Warning

Switch off the engine, remove the key and pull the handbrake before carrying out any maintenance or repairs on the machine.



Warning

Flying objects. Be sure to keep a distance to the machine when it is running.



Warning

Always be aware of overhead lines. Between the electric masts there will always be a risk of touching the overhead lines. In case of doubt - contact the local power plant for instructions on safety distances.



Warning

Check every 8 hours that all bolts / nuts are tightened.



Warning

Read the instructions manual carefully before using this machine. Follow all instructions and safety precautions when using the machine.



Warning

The machine continues to rotate after stopping. Keep your distance until the machine comes to a complete standstill. Remember to use the hand brake and turn off the engine.



Warning

while it is running.

Keep a distance from people and animals.

Turn the trimmer off immediately if people or animals come close to the machine.



Warning

Oil under high pressure - If there is a leak, avoid skin contact / inhalation

Description

GreenTec cutterbar is intended only for normal use in agricultural and landscaping or similar work.

The hedge trimmer is designed for general hedge trimming within landscaping, gardening, agriculture, forestry or similar areas of application.

Trimming can be done vertically and horizontally.

The thickness of branches to be cut must not exceed 40 mm.

Overview of the cutterbar, type plate, warning plates and instruction plate

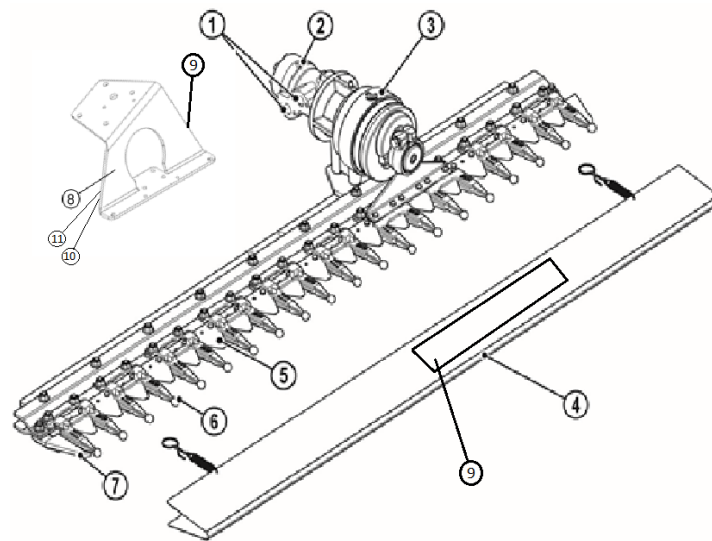

1 – Cutterbar build up

Pos.	Beskrivelse
1	Hydraulic connections
2	Hydraulicmotor
3	Pro-Drive knife drive
4	Knife guard
5	Knife
6	Guards
7	Safety guard
8	Adapter, several types (See Partsbook)
9	Warning signs, on the blade guard and behind the adapter
10	Type plate, behind the adapter
11	Instruction plate, behind the adapter

Layout and function

The hedge trimmer consists essentially of a profiled, stationary bar that is equipped with guards. These guards contain the knife that is driven by the Pro-drive knife drive (planetary drive) and a hydraulic motor.

The hedge trimmer are with 2 types of hydraulic motors:

- OMR 80 with Flow from 15 - 30 L/min
- OMR 100, with flow from 20 - 40 L/min

The hedge trimmer can be mounted on several tool frames or hydraulic reach trimmers:

HXF 2302, HXF 2302 TELE,
HXF 2802, HXF 2802 TELE,
HXF 3302, HXF 3302 TELE,
Scorpion 4- 6- 8 by using various adapters.

The tool frames and hydraulic reach trimmers should have an oil flow that is suitable for the Hedge Trimmer's engine. It is the responsibility of the owner/operations manager to ensure that the max. oil flow on the hedge trimmer's engine is not exceeded.

Adapters come in left and right versions. Adapters for other tool carriers are also available, as well as quick-change adapters. See options on the www.greentec.eu website under Equipment for the HL Hedge Trimmer or in the spare parts book for the HL hedge trimmer.

The hydraulic connection can be screwed together directly or mounted with quick couplings. If quick couplings are used, GreenTec recommends flat-face quick couplings, as it is easier for the oil to pass through them.

In addition, the HL hedge trimmer can be mounted on vehicles by means of a technically suitable mechanical and hydraulic connection (with screw or quick couplings) which the manufacturer of the vehicle or tool carrier should have produced in such a way that it is suitable for the hedge trimmer. It is important that the vehicle used has CE marking.

Springs are used for mounting the knife guard and safety guard onto the hedge trimmer.

Technical data





Cutterbar HL

Type	HL 152-S	HL 182	HL 212	HL 242
Working width	150 cm	180 cm	210 cm	240 cm
Cutting depth	Maks. 40 mm	Maks. 40 mm	Maks. 40 mm	Maks. 40 mm
Working speed	Maks. 2 km/t	Maks. 2 km/t	Maks. 2 km/t	Maks. 2 km/t
Dimensions	155 x 20 x 50 cm	186 x 20 x 50 cm	216 x 20 x 50 cm	247 x 20 x 50 cm
Weight (without hydraulic motor, with knife guard)	58,5	66	73,5	81

Hydraulic motor

Type	OMR 80	OMR 100
Weight	6,12 kg	6,24 kg
Permanent pressure	Maks. 175 bar	Maks. 175 bar
Oil quantity	15 til maks. 30 l/min.	20 til maks. 40 l/min.
Rotational speed	Maks. 400 o/min.	Maks. 400 o/min.
Max. torque for permanent pressure	17 daNm	23 daNm
Oil type	Hydraulicoil ISO VG 46	Hydraulicoil ISO VG 46

Attachment and removal

⚠ WARNING!	
	<p>Non-secured carrier vehicle!</p> <p>Danger of injury if the carrier vehicle is not secured during assembly, maintenance and repair work.</p> <ul style="list-style-type: none"> ▶ Shut off the motor and remove the ignition. ▶ Secure the carrier vehicle so that it cannot start up or roll away inadvertently.
⚠ WARNING!	
	<p>Running machine!</p> <p>Danger of injury from machine components that are in operation or moving.</p> <ul style="list-style-type: none"> ▶ Make sure that no one is in the turning and swivelling range of the machine.
⚠ WARNING!	
	<p>Knife coast-down!</p> <p>Danger of injury from coast-down of knife during assembly, maintenance and repair work.</p> <ul style="list-style-type: none"> ▶ Wait until the knife has come to a complete stop.
⚠ WARNING!	
	<p>Hydraulic system under pressure!</p> <p>Danger of injury from emerging hydraulic oil under high pressure during assembly, maintenance and repair work.</p> <ul style="list-style-type: none"> ▶ Depressurize the hydraulic system before working on the hedge trimmer.
⚠ CAUTION!	
	<p>Danger of cutting injuries from sharp knife sections!</p> <p>When attaching the hedge trimmer to the carrier vehicle or implement carrier and when working on the mechanical or hydraulic connection there is a danger of cutting injuries from the sharp knife sections.</p> <ul style="list-style-type: none"> ▶ Make sure that the knife guard is mounted.
ATTENTION!	

	<p>Danger of machine damage!</p> <p>Incorrect working methods can result in damage and malfunctions in the hedge trimmer and the carrier vehicle or implement carrier.</p> <p>▶ Have all work carried out by trained and qualified personnel.</p>
--	--

Delivery

- ▶ Check the delivered items for any damage during transport and check the items against your order.
- ▶ Check that the delivery is complete.
- ▶ If you have any complaints, you should inform the manufacturer in writing immediately and, in the event of damage during transport, the forwarding agent as well.

Mounting

The hedge trimmer can be mounted on GeenTec's tool frames HXF 2302, HXF 2802 or HXF 3302 (as well as all HXF Tele models)

In addition, it can also be mounted on Hydraulic Reach Trimmers Scorpion 4, 6 or 8. Always bear in mind that the max. oil flow that the hedge trimmer needs is also the flow that the tool frame or hydraulic reach trimmer is able to supply.

In this description, the HL 182 is mounted on a HXF 2802 (note that the oil flow on the HXF 2802 should be 40 l/min).

If you wish to mount the hedge trimmer on a Scorpion, the adapter for a Scorpion must be installed, and the procedure is then identical to the one given in this description.

Find a good, large space with a good, firm base, place the pallet with the hedge trimmer here and take the HXF out, unfold it into a working position, and turn the rotating head all the way round to the horizontal position (with either the cylinder or the top pole).

Position the HXF's tool hold over the hedge trimmer's hold, so that they almost touch each other.

Finely adjust the positioning of the hedge trimmer with a pallet jack and secure using the 4 bolts supplied, with washers and locking nuts.



2 - Hækklipperen boltes på Redskabsrammen.

Mount hoses

⚠ WARNING!



Avoid skin contact with the hydraulic oil!

- ▶ Know and handle the hydraulic oil in the vehicle correctly.
- ▶ Use all necessary protective equipment when handling the oil.
- ▶ Use a drip tray for collecting oil leaks.
- ▶ Dispose of oil in accordance with regulations



3 – 2 pcs. hydraulic hoses are mounted.

All hedge trimmers have 2 connections, press and return.

The engine can run both ways, the hedge trimmer's blades have the same movement whatever the engine's direction of rotation. Therefore the hydraulic hoses can be mounted the other way round.

Mount the 2 hydraulic hoses

The drainage hose is NOT used. It should be capped off and secured with strips.

Start-up

- ▶ Check that the hedge trimmer, the tool frame and the vehicle are free from defects. If a part is missing or loose or damaged, the tool must not be used.
- ▶ Check that the mechanical and hydraulic connections, the hydraulic hoses and transport fittings (e.g. lights and warning and protective devices) are fixed properly and fully functional.
- ▶ Remove any supports.
- ▶ Drive out where there is a space of 5 m all the way around the vehicle.
- ▶ Unfold the tool frame.
- ▶ Demount the protective guard by pulling the hook on the rear edge of the cutterbar.



Figur 4 – Protection guard
- 2 stk. kroge holder
afskærmningen.

⚠ WARNING!	
	<p>Running machine</p> <p>There is a risk of personal injury from machine parts that are running or moving.</p> <ul style="list-style-type: none"> ▶ Check that there are no people within the danger zone, where they can be hit by the machine.

- ▶ Let the vehicle idle and carefully open the hydraulic oil
- ▶ The trimmer now starts to work.
- ▶ Let the machine idle until the oil is at operating temperature. If the temp. is below -10° C, this could take up to 15 minutes.
- ▶ Now increase the vehicle's speed until the trimmer is supplied with the correct quantity of oil. From 15 to 40 l/min, depending on engine type.
 - OMR 80 requires 15-30 l/min
 - OMR 100 requires 20-40 l/min

 Instruktion

The max. quantity of oil generally ensures optimal power and best performance, but if hedges are dense with thin branches and leaves, a lower rev. per min. count can give better results.

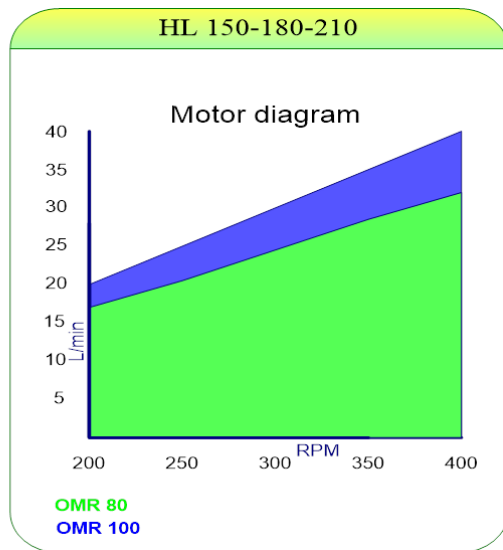

5, Sammenhæng mellem olieflow (L/min) og omdr/min (RPM)

 Instruktion

After the hedge trimmer is started up for the first time, you should check the tension torque on all screws after 10 minutes' running.

Hedge trimming

Start the trimmer up as described in the previous section.

Adjust the height and incline of the hedge and the hedge trimmer. Trim at the bottom first, and then work your way up, and finally trim horizontally.

All GreenTec hedge trimmers have an angle on the cutterbar in relation to the direction of travel. This ensures an optimal cut, as the branches often bend slightly in the direction of travel, and the newly cut branches easily “slip past” the cutter bar.



Start the hedge trimming carefully, find the best speed (max. 5 km an hour)
The user must ensure first and foremost that the result of the trimming is satisfactory.

What the user must pay particular attention to:

- ▶ Driving and steering of the vehicle:
 - Driving should be constant
 - Raise or lower the trimmer to cut at the desired height
 - The result is not as good if the road is uneven (steer more and drive more slowly)
 - Drive carefully round bends and corners
- ▶ The driving speed should be constantly adapted (max. 5 km an hour)
 - The course of the road,
 - The denseness of the hedge
 - The thickness of the branches (max. 60 mm)
- ▶ Oil flow can be reduced = the blade speed is reduced
 - A lower blade speed can improve the result of the trimming; thin branches or leaves in particular may evade the blades, so a lower blade speed could make it easier for the branches to reach the blades.

⚠ CAUTION!



The user should take frequent short breaks!

The user must be attentive and alert during trimming.

The working position (on the driver's seat, bent over while having to look straight up and ahead) is ergonomically not appropriate, especially when working at heights

It is recommended therefore that the user takes frequent short breaks and to do stretch exercises if necessary.

Transport

If the hedge trimmer is mounted on the vehicle or tool carrier, you must follow the instructions for transport given below.

- ▶ Check that the Blade Guard and safety guard are mounted.
- ▶ To prepare the vehicle or tool carrier correctly for transport, you must follow the instructions provided for the tool carrier.



Figur 7 - Transport stilling med HXF-redskabsramme

Demounting

- ▶ Demount the hedge trimmer on a secure, solid and even surface.
- ▶ Demounting follows the procedure for mounting in reverse.

IF QUICK COUPLINGS ARE NOT MOUNTED on the hydraulic hoses:

Pay particular attention to cleanliness when the hydraulic hoses are demounted and capped.

Avoid skin contact with the oil and collect oil seepages.

Storage and moving the machine

⚠ CAUTION!



Danger of cutting injuries from sharp knife sections!

During storage and transport of the hedge trimmer there is a danger of cutting injuries from sharp knife sections.

- ▶ Make sure that the knife guard is mounted

Storage

- ▶ Check that the Blade Guard and safety guard are mounted.
- ▶ Put the hedge trimmer aside in a dry and clean place.
- ▶ Make sure that the hydraulic system is not contaminated. Close off the hydraulic engine's connections and the hydraulic hoses with the caps.
- ▶ Ensure there is no risk of the hedge trimmer overturning or falling during storage. Secure the hedge trimmer by using a suitable rest or support.
- ▶ Place all hydraulic hoses over the top of the hedge trimmer, so there is no risk of anyone stumbling/tripping over them.
- ▶ Clean the hedge trimmer thoroughly before storage. Dirt attracts moisture resulting in an increased build-up of rust.
- ▶ Repair any damage to lacquer.
- ▶ Lubricate all lubrication points in accordance with the directions on the lubrication plate after cleaning.
- ▶ Apply rust-protection oil to the whole machine, in particular fingers and cutterbar, to avoid the formation of rust on the blade.

Driving during transport

If the hedge trimmer is mounted on the carrier vehicle or implement carrier, observe the following instructions for transport.





- ▶ Make sure that the knife guard is mounted.
- ▶ Check that the hydraulic engine's connections and the hydraulic hoses are closed off with the caps.
- ▶ Secure loosely hanging hydraulic hoses so that there is no risk of anyone stumbling/tripping or getting caught up in them.
- ▶ The hedge trimmer must be secured so that there is no risk to other road users when in use.



Instruktion

To prevent damage and to facilitate loading and unloading, transport on euro pallets or expendable pallets is recommended.

Maintenance

⚠ WARNING!	
	<p>Non-secured carrier vehicle!</p> <p>Danger of injury if the carrier vehicle is not secured during assembly, maintenance and repair work.</p> <ul style="list-style-type: none"> ▶ Shut off the motor and remove the ignition. ▶ Secure the carrier vehicle so that it cannot start up or roll away inadvertently.
⚠ WARNING!	
	<p>Knife coast-down!</p> <p>Danger of injury from coast-down of knife during assembly, maintenance and repair work.</p> <ul style="list-style-type: none"> ▶ Wait until the knife has come to a complete stop.
⚠ WARNING!	
	<p>Hydraulic system under pressure!</p> <p>Danger of injury from emerging hydraulic oil under high pressure during assembly, maintenance and repair work.</p> <ul style="list-style-type: none"> ▶ Depressurize the hydraulic system before working on the hedge trimmer.
⚠ CAUTION!	
	<p>Danger of cutting injuries from sharp knife sections!</p> <p>During assembly, maintenance and repair of the hedge trimmer there is a danger of cutting injuries from sharp knife sections.</p> <ul style="list-style-type: none"> ▶ Wear cut-resistant safety gloves.
ATTENTION!	
	<p>Danger of machine damage!</p> <p>Incorrect working methods can result in damage and malfunctions in the hedge trimmer and the carrier vehicle or implement carrier.</p> <ul style="list-style-type: none"> ▶ Have all work carried out by trained and qualified personnel.

Maintenance schedule

Period	Maintenance tasks	Cleaning	Inspection	Lubrication	Replacement
10 minutes after first start-up	Tightening torques for bolts and nuts		X		
as needed	Hedge trimmer	X			
	Sections				X
	Knives				X
	Guards				X
	Safety fingers				X
	Wear plates				X
	Knife head				X
before each use	Hedge trimmer		X		
every 50 hours	Pro-drive knife drive			X	
	Head bearing			X	
	Tightening torques for bolts and nuts		X		

Required tools

You will need the following tools for maintenance of the hedge trimmer:

► Torque spanner

- Tightening torque **115 Nm** for bolts M12 x 40 (Pro-drive knife drive)
- Tightening torque **115 Nm** for bolts M12 x 30 (motor mount and Pro-drive knife drive)
- Tightening torque **48 Nm** for nuts M10 (guard)
- Tightening torque **15 Nm** for bolts M6 x 22, M6 x 18 (knife connection) and nuts M6 (sections)
- Tightening torque **81 Nm** for bolts M10 x 35 (head bearing)
- Tightening torque **> 72 Nm** for bolt M10 x 45 (knife head lug)

► Wrench set

- Socket set can be motorised or air-powered
- Open-end wrench set

Cleaning

ATTENTION!	
	<p>Danger of machine damage!</p> <p>Some parts of the hedge trimmer can become very hot during operation. Cleaning with cold water immediately after use can result in damage and malfunctions in the hydraulic, motor or control components.</p> <p>▶ Allow the hedge trimmer to cool before cleaning.</p>

Regular cleaning and subsequent visual inspection will help to detect and remedy damage and discrepancies early on.

- ▶ Clean the hedge trimmer and carrier vehicle or implement carrier after each use and then conduct a visual inspection.
You can use a pressure washer to clean the hedge trimmer.
- ▶ Be careful not to damage any exposed seals and electrical connections.
- ▶ Maintain a sufficient distance.
- ▶ Afterwards, dry the hedge trimmer with compressed air.
- ▶ After cleaning and before storing the hedge trimmer, lubricate the grease points in accordance with the information on the lubrication sticker. Also observe the lubrication instructions of the manufacturer of the carrier vehicle or implement carrier.
- ▶ Clean and grease the connection to the carrier vehicle or implement carrier
- ▶ Rust-protection oil is applied to the hedge trimmer after washing

Conduct a visual inspection

Operate the hedge trimmer only if it is in perfect working order.

- ▶ Check the hedge trimmer for loose, damaged, missing and worn parts to ensure operational safety.
- ▶ Repair any damage and replace any missing parts before using or continuing use of the machine.

Check tightening torques

- ▶ Make sure all bolts and nuts on the hedge trimmer are tight. The specified tightening torques can be found in chapter [Required tools](#) and chapter [Tightening torques](#) see chapter [Required tools](#) and [Torque spanner](#)

Parts replacement

Replacing sections

In case of breakage, single sections of the installed knives can be replaced.

Removing a section

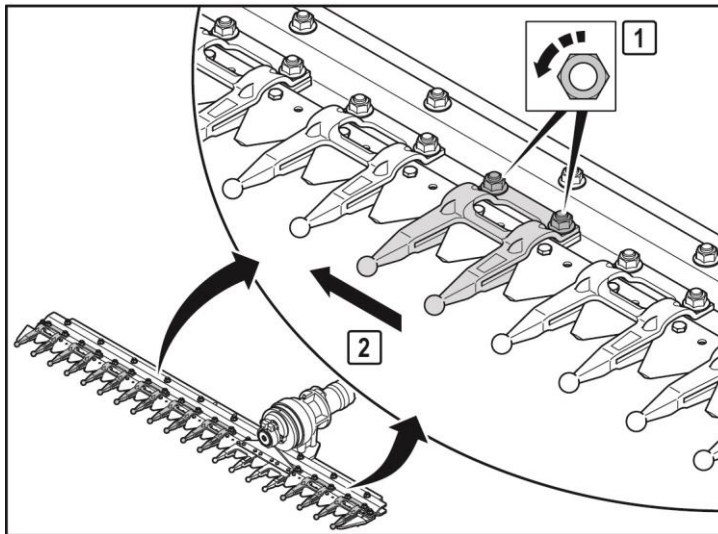

- ▶ Unscrew the nut of the double guard on the damaged section and remove the bolts.
- ▶ Push the double guard to the side in order to access the knife bolts

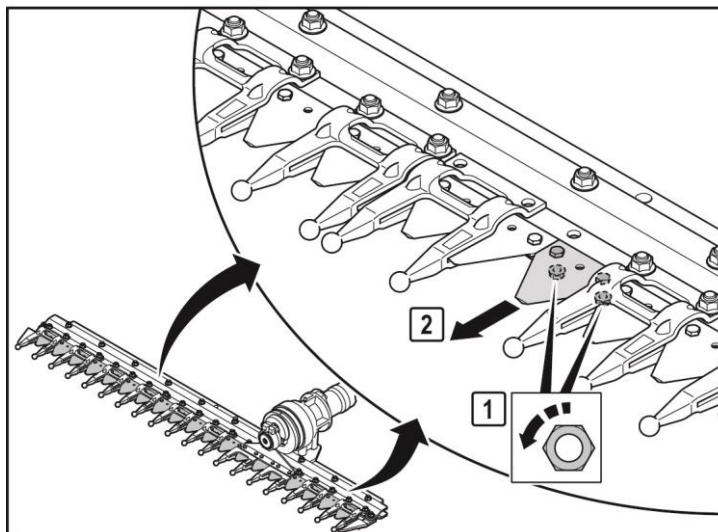

- ▶ Loosen the nuts on the damaged section and tap the serrated stud bolts to remove them.
- ▶ Remove the section from the knife.



Installing the blade tooth

INFO: As the cutterbar's fingers are supplied with a double cutting edge (on the topside and the underside), the blade teeth can be turned in both directions.

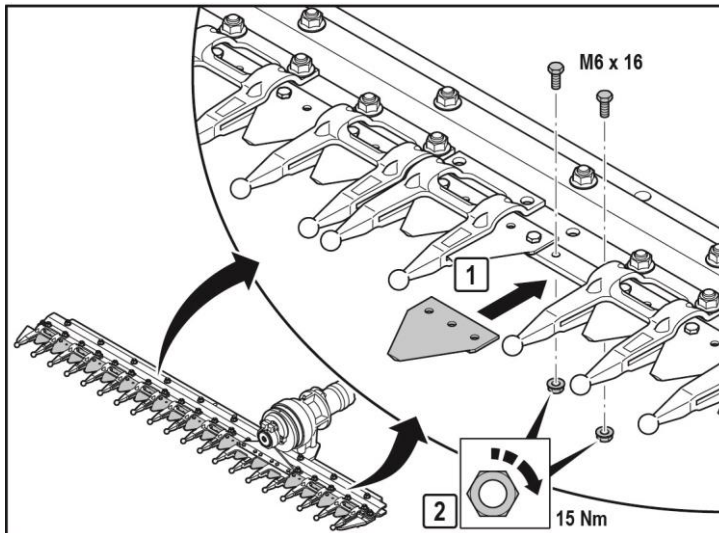

Mounting a section

- ▶ Position the new section on the knife.
 - ▶ Insert the serrated stud bolts from above.
- Always use **new** serrated stud bolts!
- ▶ Tighten the nuts to the specified tightening torque.

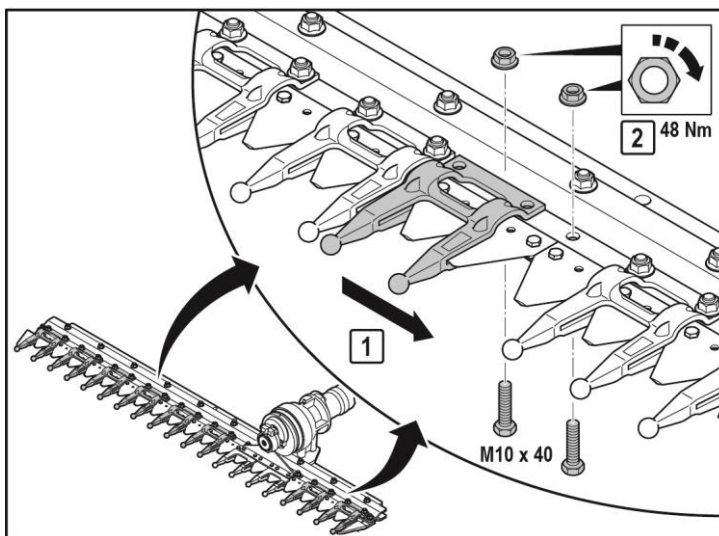

- ▶ Push the double guard back
- ▶ Insert the bolts.
- ▶ Tighten the nuts to the specified tightening torque.

Changing knives

If the sections are excessively worn, the entire knife must be replaced.

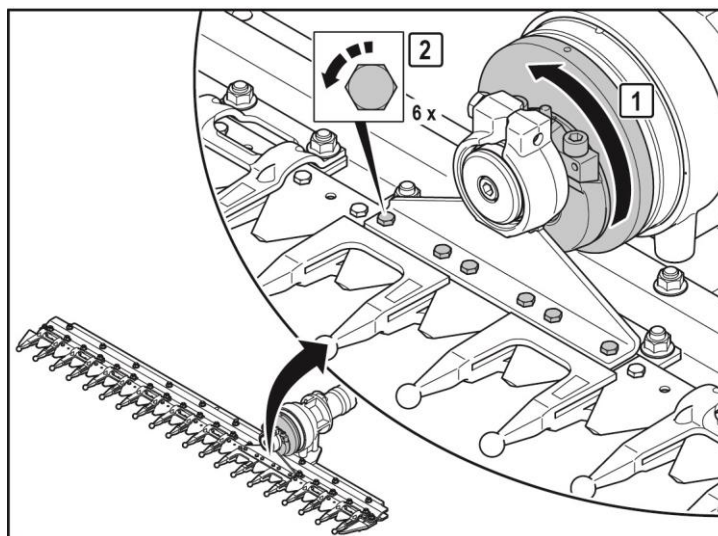

Removing knives

- ▶ Align the knife stroke so that the bolts on the head bearing are on top.
- ▶ Unscrew the bolts on the knife head.

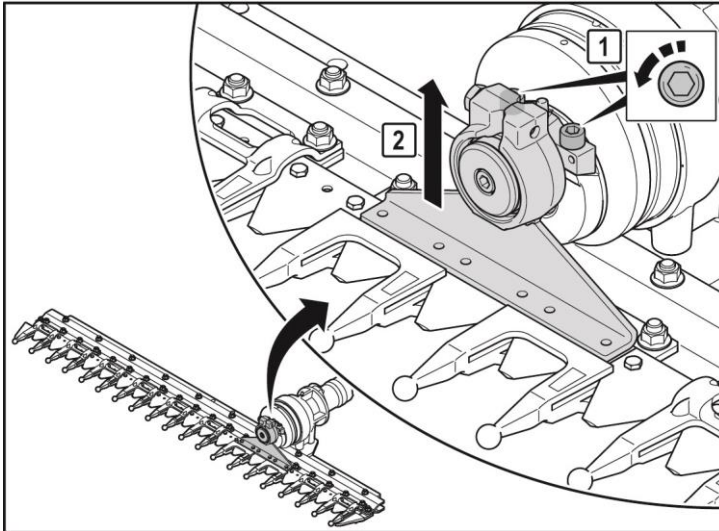

- ▶ Unscrew the bolts on the head bearing.
- ▶ Remove the knife head.

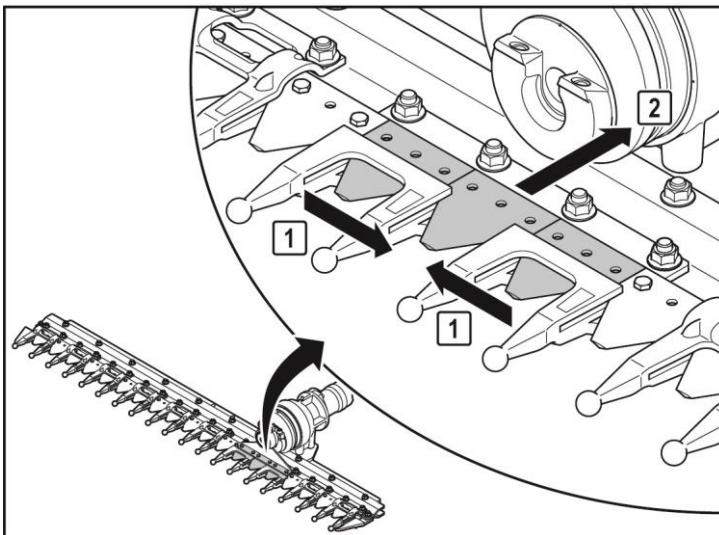

- ▶ Remove the three loose sections toward the rear between the two first guards

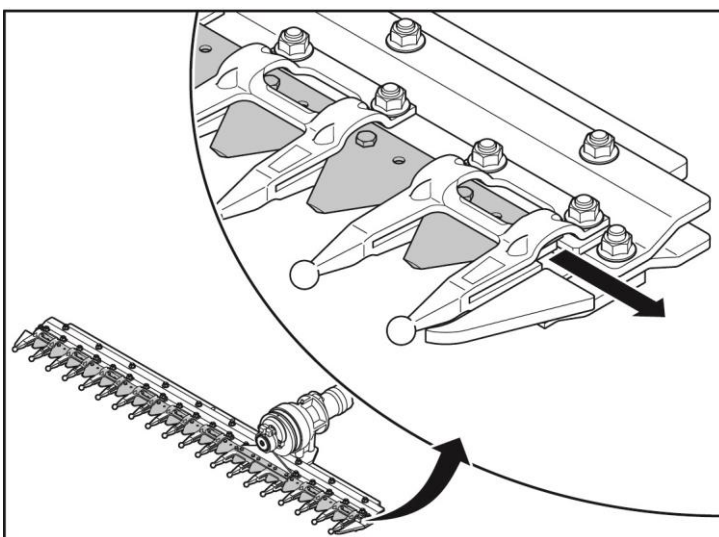

- ▶ Pull the knife carefully to the side to remove it from the finger bar.

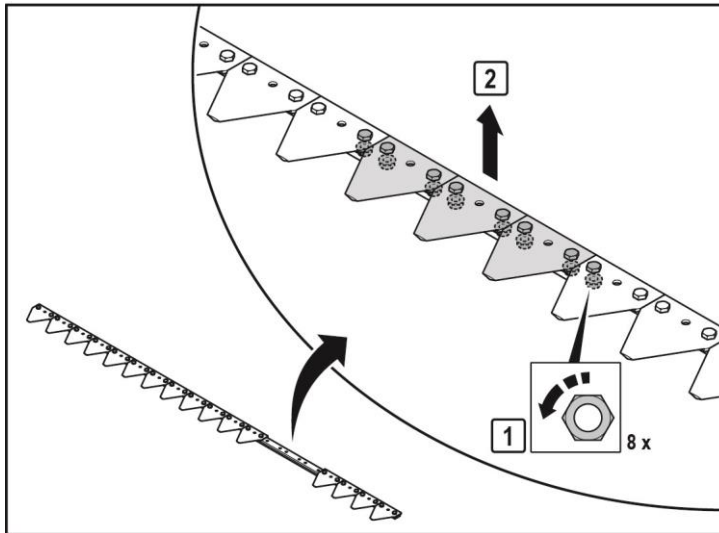

Preparing a new knife for mounding

- ▶ Loosen the nuts on the three sections on which the knife head is to be mounted.
- ▶ Loosen the nuts on both sides of the next section.
- ▶ Tap the serrated stud bolts to remove them.
- ▶ Remove the three sections.

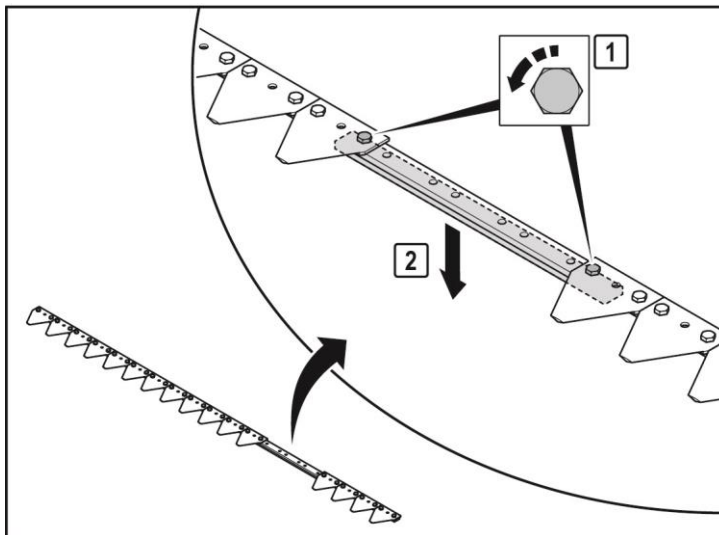

- ▶ Loosen the two outer bolts on the knife connection of the **old** knife.
- ▶ Remove the knife connection.

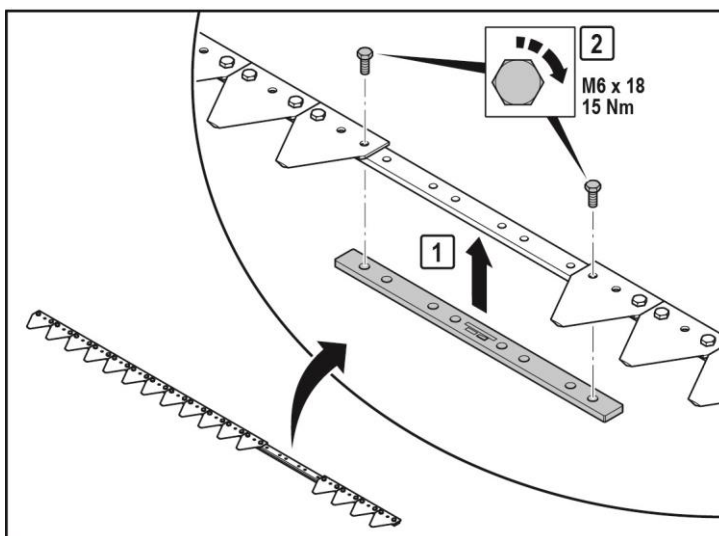

- ▶ Mount the knife connection on the **new** knife.
- ▶ Make sure that the protrusions of the press-in nuts point upward and are seated properly during assembly.
- ▶ Tighten the two bolts to the specified tightening torque.

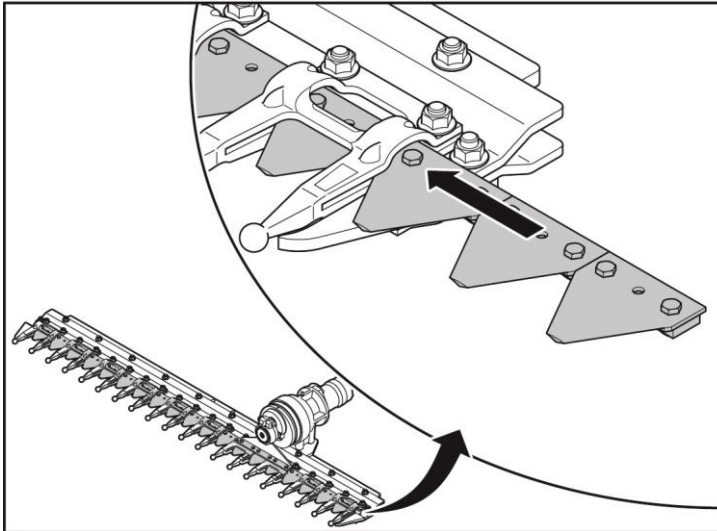

Mount the knife

► Push the new knife carefully into the guide bar.

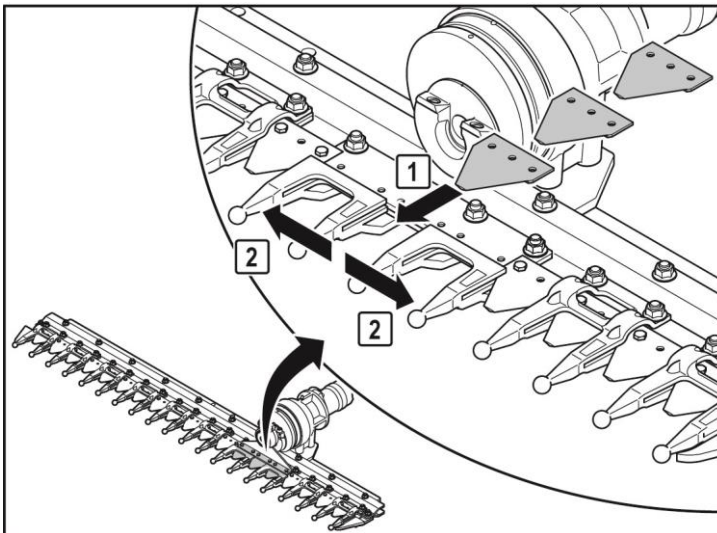

► Insert the three loose sections from the rear between the two guide fingers and push them into the mounting position.

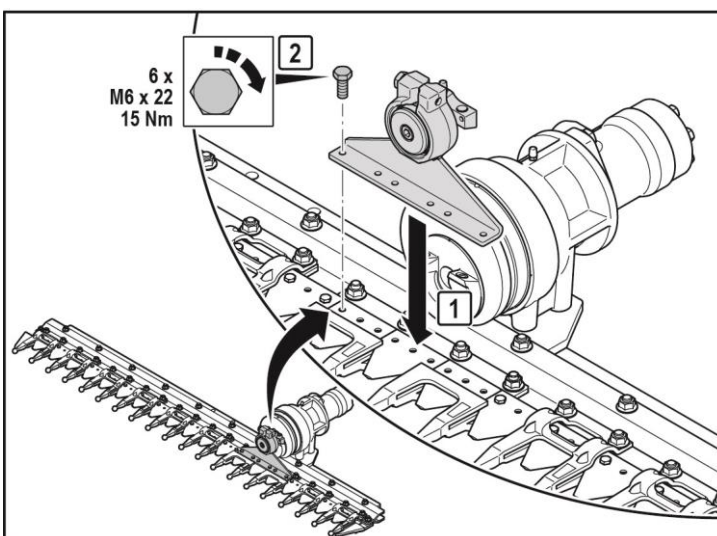

► Place the knife head on the sections.

► Tighten the bolts to the specified tightening torque.

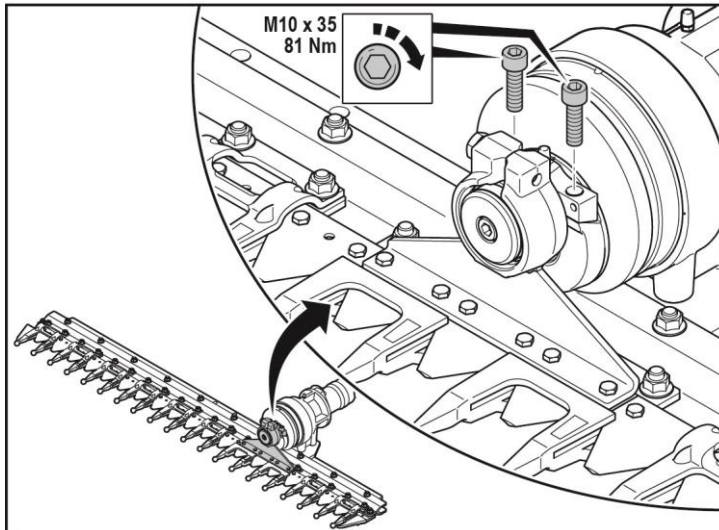

► Tighten the bolts on the head bearing to the specified tightening torque.

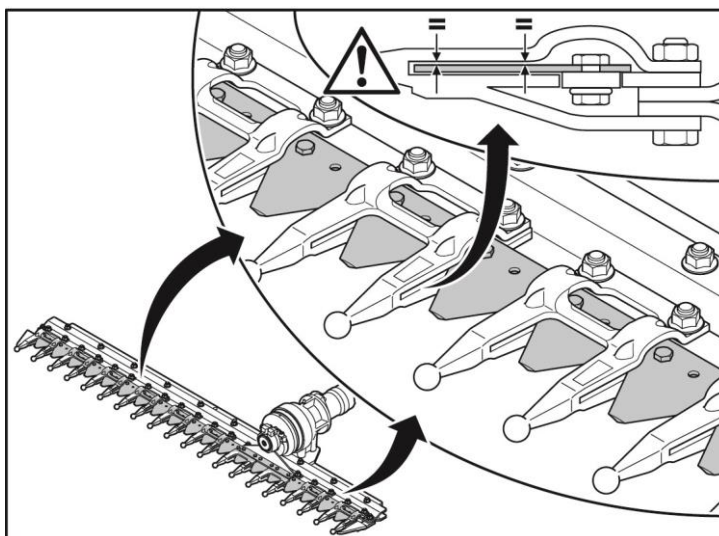

► Check the cutting gap for parallelism.
 ► Observe the section while it runs very slowly.
 If the knife scrapes or does not run straight in the cutting gap, the cause must be determined and eliminated.

Replace the guard

A guard must be replaced if it is bent or damaged, or if the cutting gap has reached the wear mark of 5.4 mm.

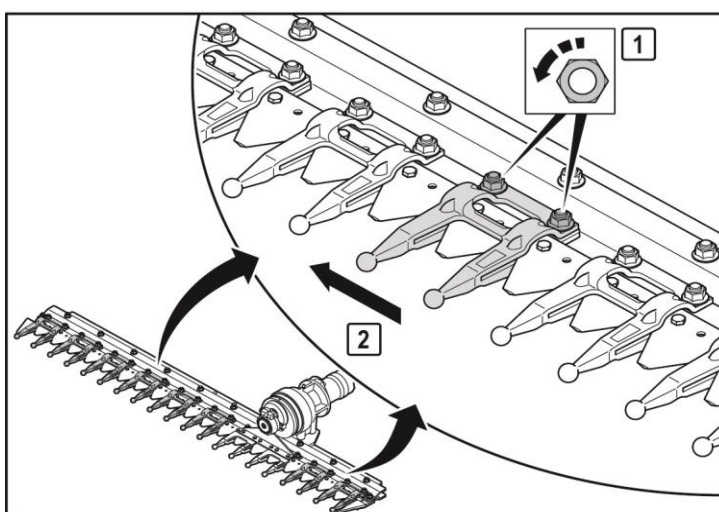

Remove the double guard

► Unscrew the nuts on the damaged double guard and remove the bolts.
 ► Push the double guard to the side in order to access the knife bolts.

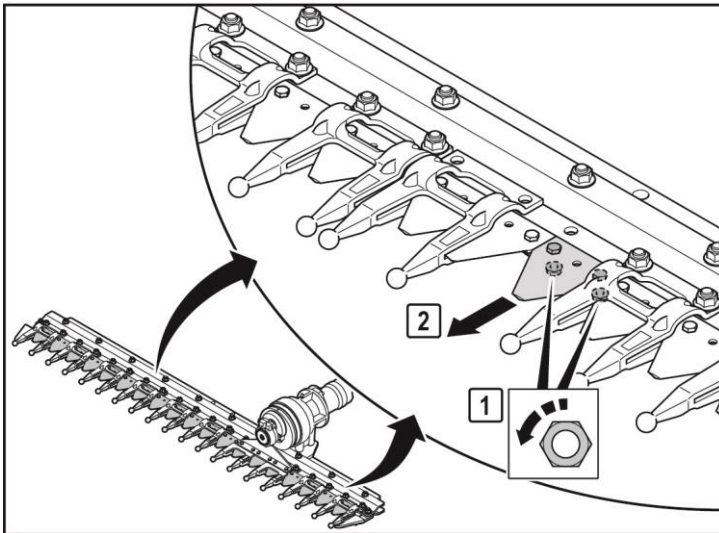

- ▶ Loosen the nuts on the corresponding section and tap the serrated stud bolts to remove them.
- ▶ Remove the section from the knife.

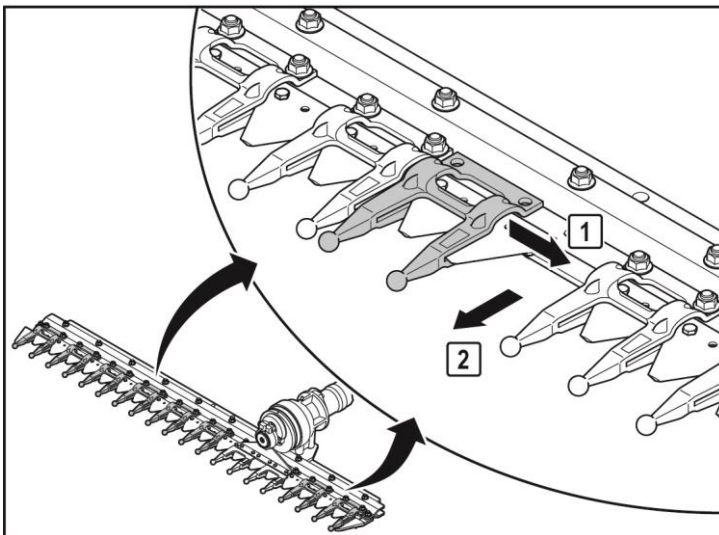

- ▶ Push the double guard through the resulting gap in the knife.

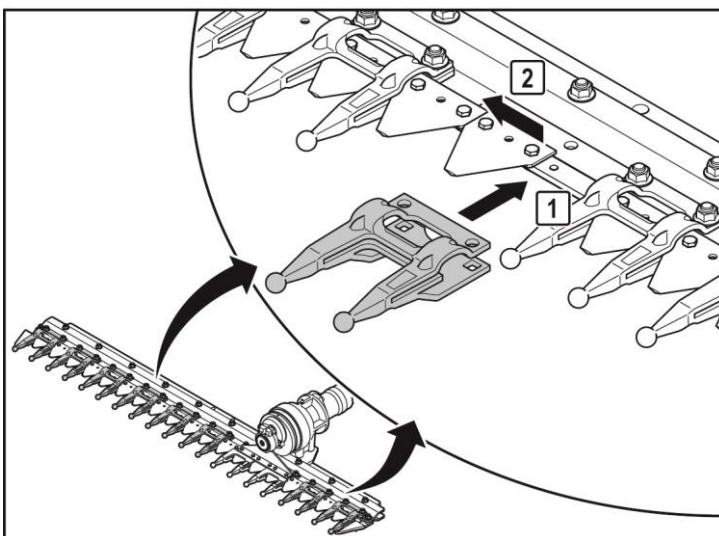

Mount the double guard

- ▶ Push the new double guard through the gap in the knife.
- ▶ Push the double guard aside.

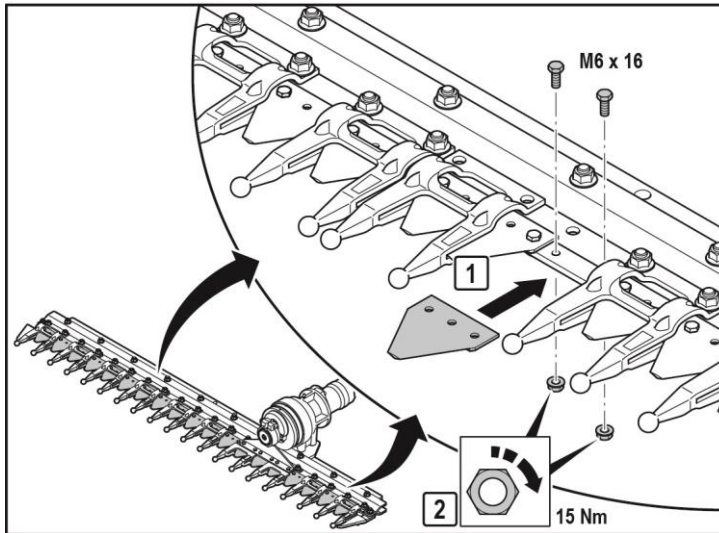

- ▶ Position the section on the knife.
 - ▶ Insert the serrated stud bolts from above.
- Always use **new** serrated stud bolts!
- ▶ Tighten the nuts to the specified tightening torque.

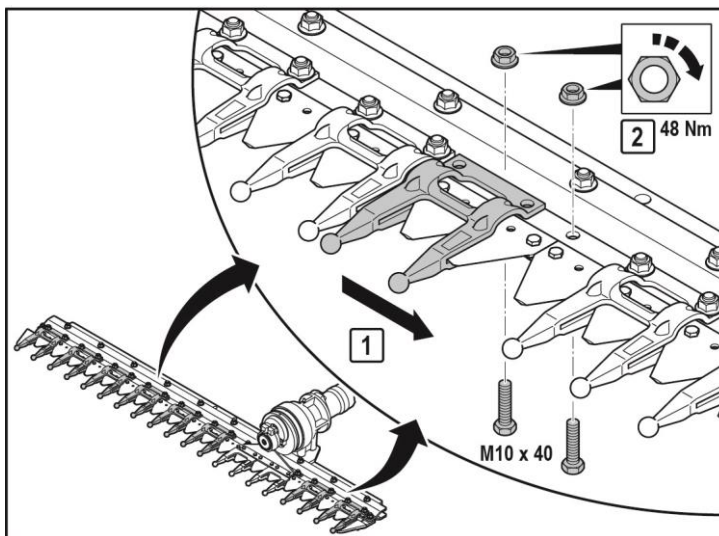

- ▶ Push the double guard back.
- ▶ Insert the bolts.
- ▶ Tighten the nuts to the specified tightening torque.

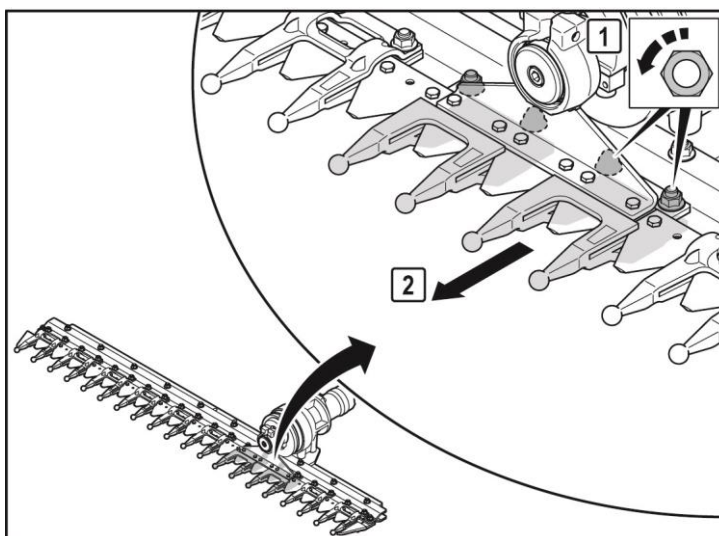

Remove the first guard V/O

- ▶ Unscrew the nuts on the first guard V/O and remove the bolts.
- ▶ Remove the first guard V/O from the profile bar.

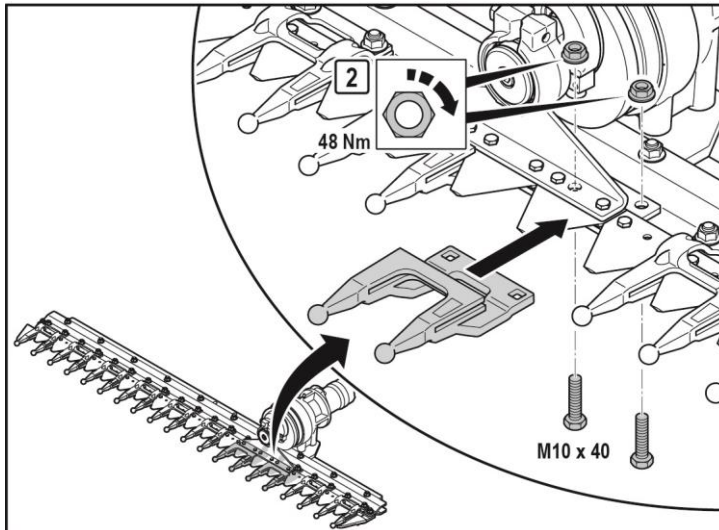

Attach first guard V/O

- ▶ Position the first guard V/O below the profile bar.
- ▶ Insert the bolts.
- ▶ Tighten the nuts to the specified tightening torque

Replace the safety finger

If the position of the safety finger on the guard is not correct, it can be aligned to correct this. Damaged safety fingers must be replaced immediately.

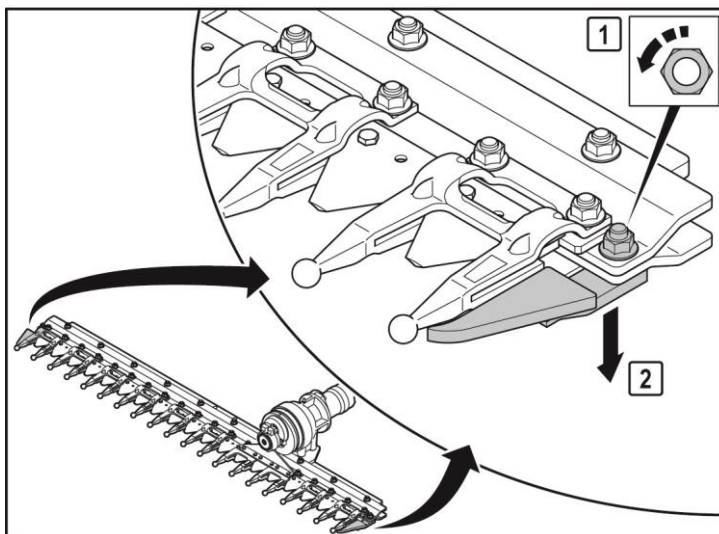

Remove the safety finger

- ▶ Unscrew the nut on the safety finger and remove the bolt.
- ▶ Remove the safety finger from the profile bar.

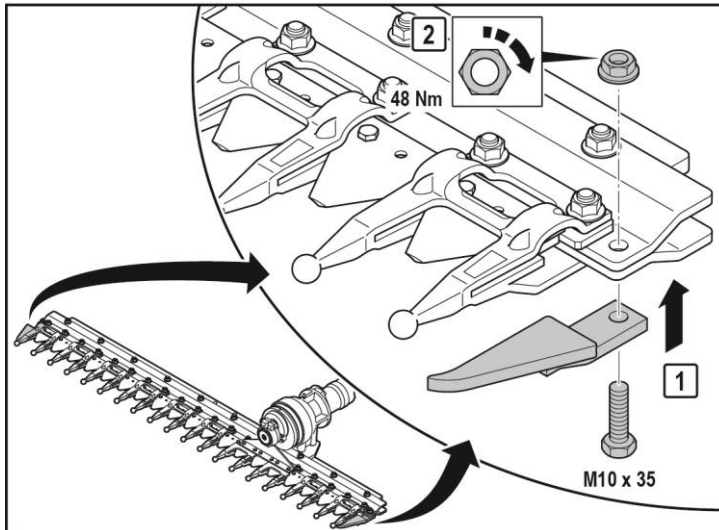

Mount the safety finger

- ▶ Position the safety finger beneath the profile bar.
- ▶ Insert the bolt and tighten the nut to the specified tightening torque.

Replace the wear plate

If the wear plates are worn, they must be replaced.

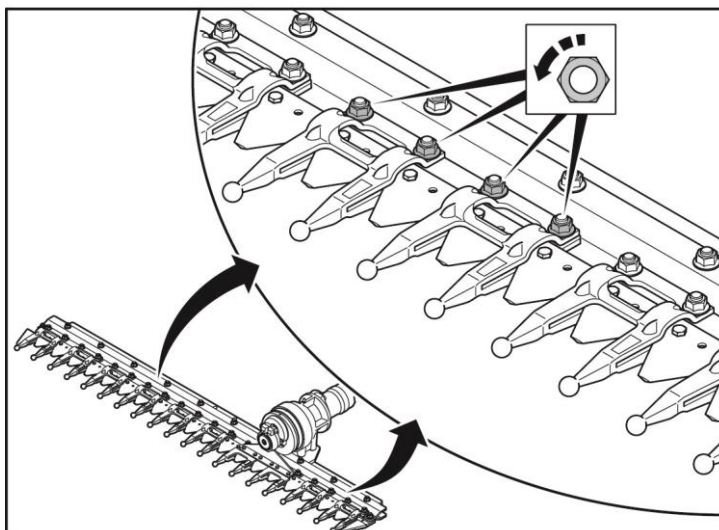

Remove the wear plate

- ▶ Skru møtrikkerne på de to dobbeltfingre ved den slide styreplade af og fjern skruerne.

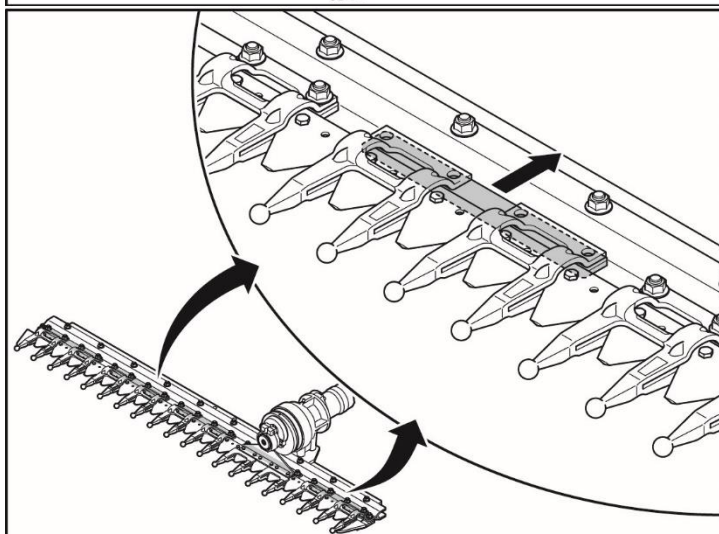

- ▶ Push the worn wear plate out to the rear over the profile bar.

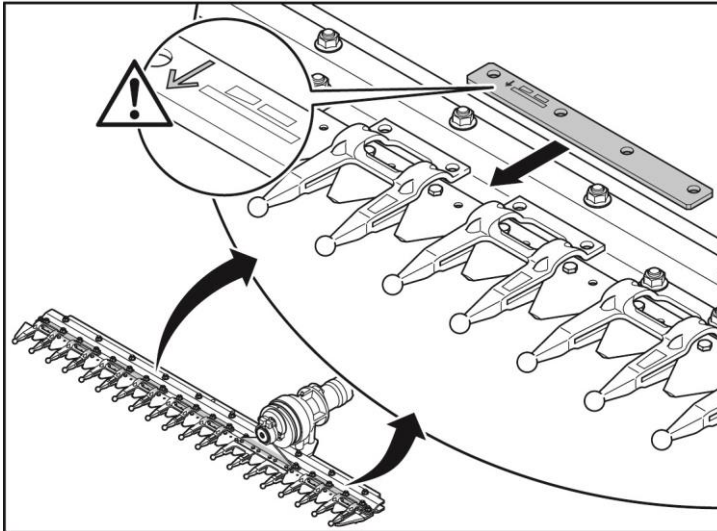

Mount the wear plater

► Push the new wear plate from the rear between the profile bar and guard. The arrow on the wear plate must point in the direction of travel.

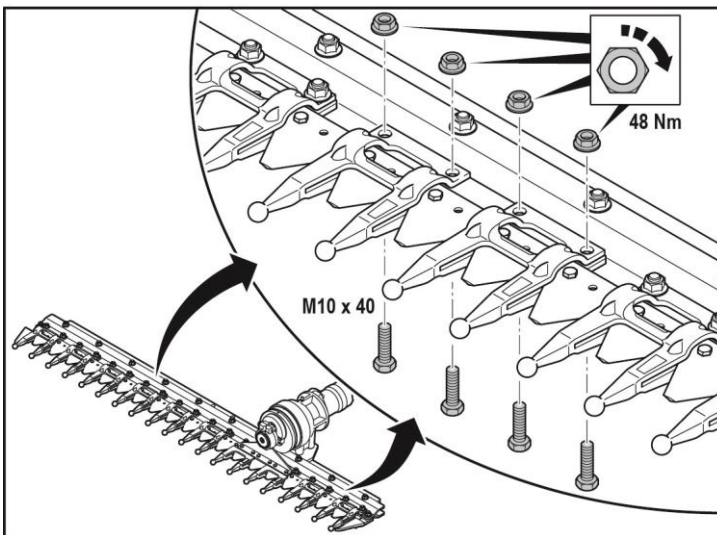

► Position the two guards correctly on the wear plate.
 ► Insert the bolts.
 ► Tighten the nuts to the specified tightening torque.

Replacing the knife head

If the knife head is bent, damaged or deformed, it must be replaced immediately.

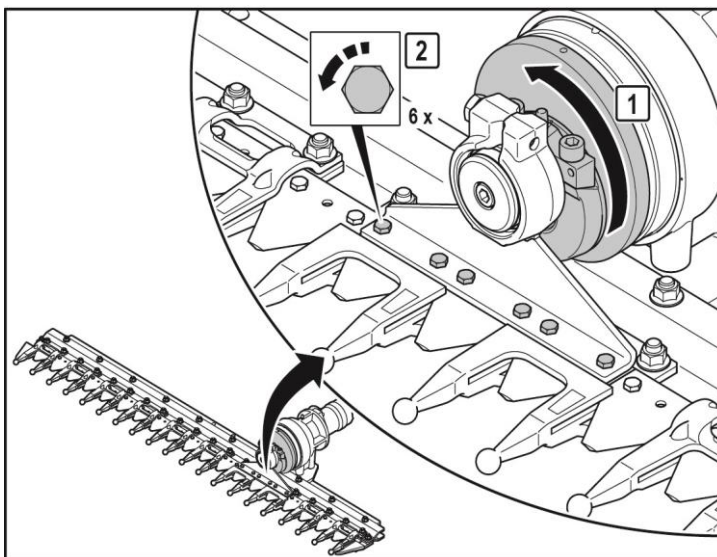

Removing the knife head

► Align the knife stroke so that the bolts on the head bearing are on top.
 ► Unscrew the bolts on the knife head.

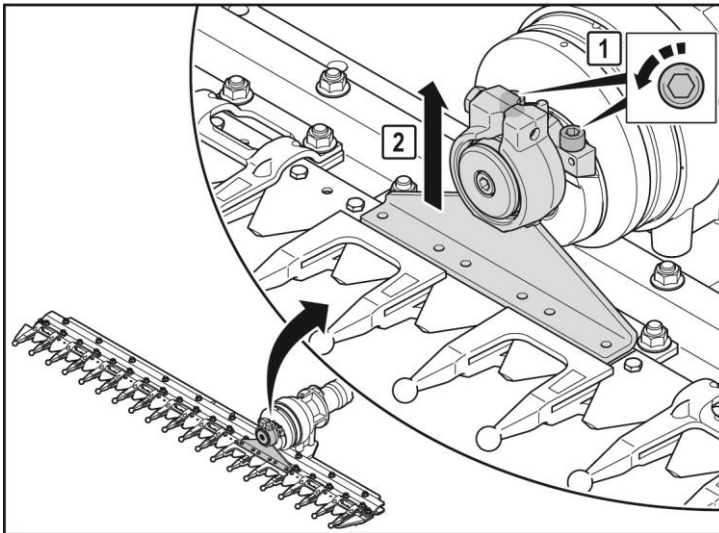

- ▶ Unscrew the bolts on the head bearing.
- ▶ Remove the knife head from the sections. Watch out for loose sections.

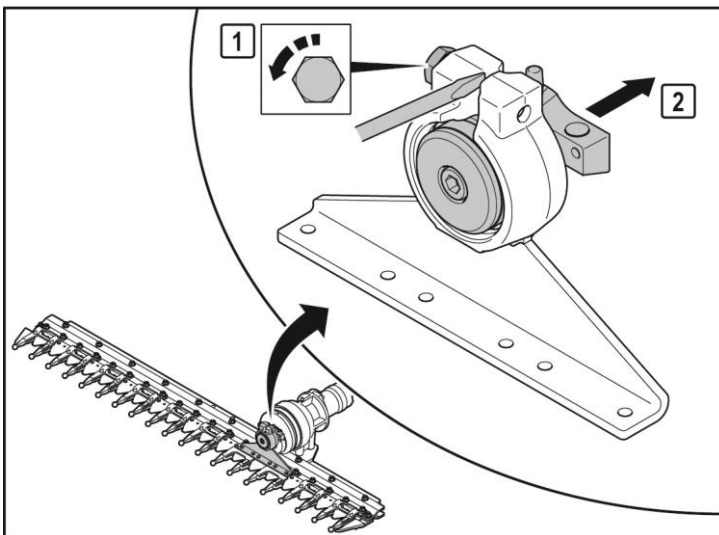

Dismantling the head bearing

- ▶ Loosen the bolt on the knife head.
- ▶ Remove the head bearing from the knife head. You can spread the knife head somewhat by inserting a small screwdriver into the slot of the knife head.

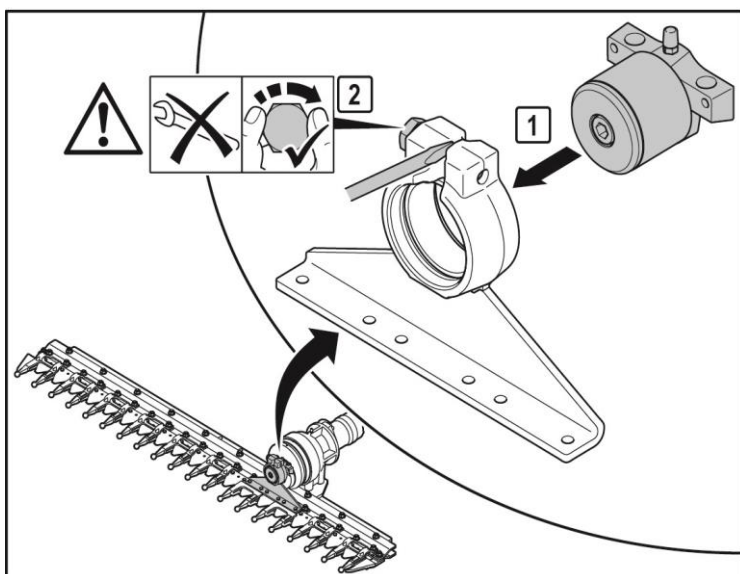

Installing the head bearing

- ▶ Insert the head bearing in the new knife head and align it roughly. You can spread the knife head somewhat by inserting a small screwdriver into the slot of the knife head.
- ▶ Tighten the bolt hand-tight.

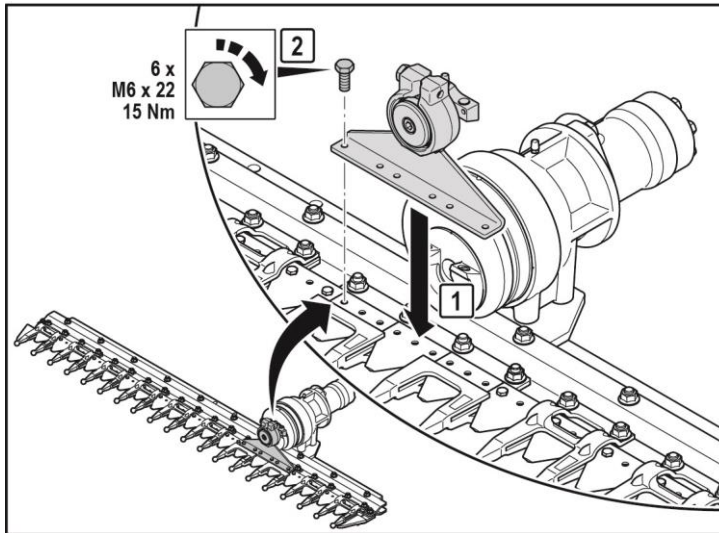

Mounting the knife head

- ▶ Place the knife head on the sections.
- ▶ Tighten the bolts to the specified tightening torque.

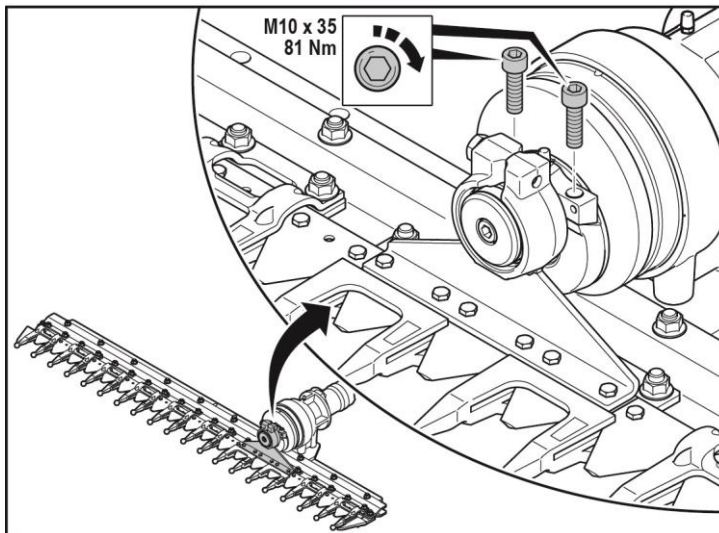

- ▶ Tighten the bolts on the headbearing to the specified tightening torque.

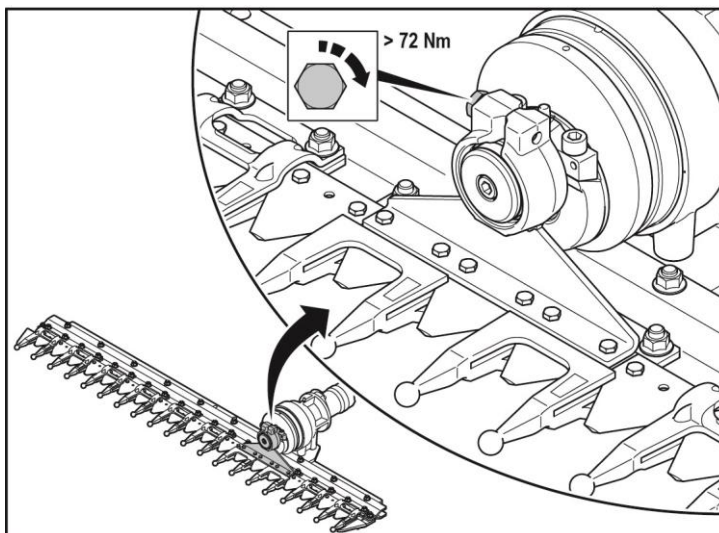

- ▶ Tighten the bolts on the head bearing to the specified tightening torque.

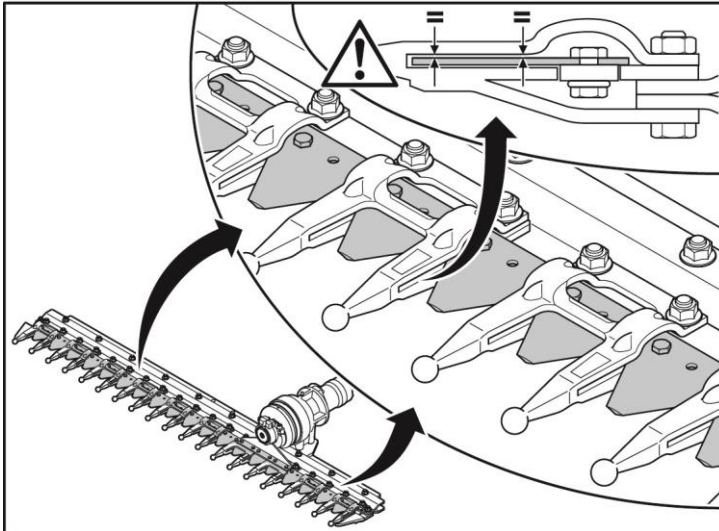

- ▶ Check the cutting gap for parallelism.
- ▶ Observe the section while it runs very slowly.
- ▶ If the knife scrapes or does not run straight in the cutting gap, the cause must be determined and eliminated.

Lubrication

The hedge trimmer has two lubrication points, one on the Pro-drive knife drive and one on the head bearing.

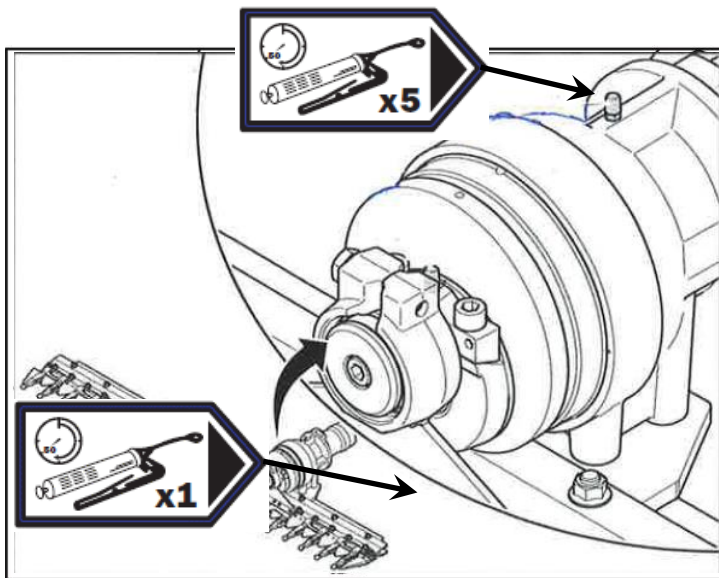

- ▶ Lubricate the grease nipples in accordance with the information on the lubrication sticker.
- ▶ Before lubricating, clean the grease nipples of any dirt or residue.
- ▶ After each lubrication, remove any emerging grease.
- ▶ The top layer is lubricated by squeezing the grease gun at least once.
- ▶ The blade drive is lubricated by squeezing the grease gun at least 5 times.

Parts

You can purchase original parts from your local dealer or directly from GreenTec.

When ordering parts, always specify the type designation, machine number and year of the respective machine.

Parts lists

Parts list and instructionsbook will follow the machine. But are always on WWW.greentec.eu.

Disposal

Disposal of packaging

The packaging consists of the following materials, which are recyclable:

- Euro pallet (IPPC)
- Construction timber (IPPC)
- Strapping band
- Packing paper
- Stretch foil

▶ These materials should always be recycled.

Disposal of machine after decommissioning

National and regional laws regulate the environmentally safe disposal of service fluids, recyclable materials and other machine components. Contact your responsible local authority for exact information about disposal. If you have questions about the materials used, you can contact our customer service department. Environmentally safe disposal of all parts requires that the parts be sorted properly.

▶ Sort parts based on the materials.

Recycling

▶ Suitable parts should always be recycled.

Troubleshooting

The following overview lists the possible causes of faults and their remedies.

Fault	Cause	Remedy
Knife does not move	Incorrect connections	Check connections, tighten threaded connections
	Pump not switched on	Switch on pump
	Foreign objects in cutting system	Remove foreign objects
	Defective guards, sections or knife head	Replace defective parts
	Defective hydraulic motor	Consult an authorized repair shop; replace defective parts
	Defective knife drive	
Material is not cut cleanly	Worn guards, sections or knives and wear plates	Replace defective parts
	Incorrect speed of knife drive	Consult an authorized repair shop
Knife drive does not pull through	Incorrect oil quantity or pressure	Consult an authorized repair shop
Defective seal on hydraulic motor	No oil leakage pipe on hydraulic motor	Consult an authorized repair shop
		Replace defective parts
		Attach oil leakage pipe, if necessary
	Disruptions	Check pressure-relief valve
Extreme oscillation or vibration of the hedge trimmer	Excessive speed at hydraulic motor or knife drive	Consult an authorized repair shop

Bilag 1

Tightening torques

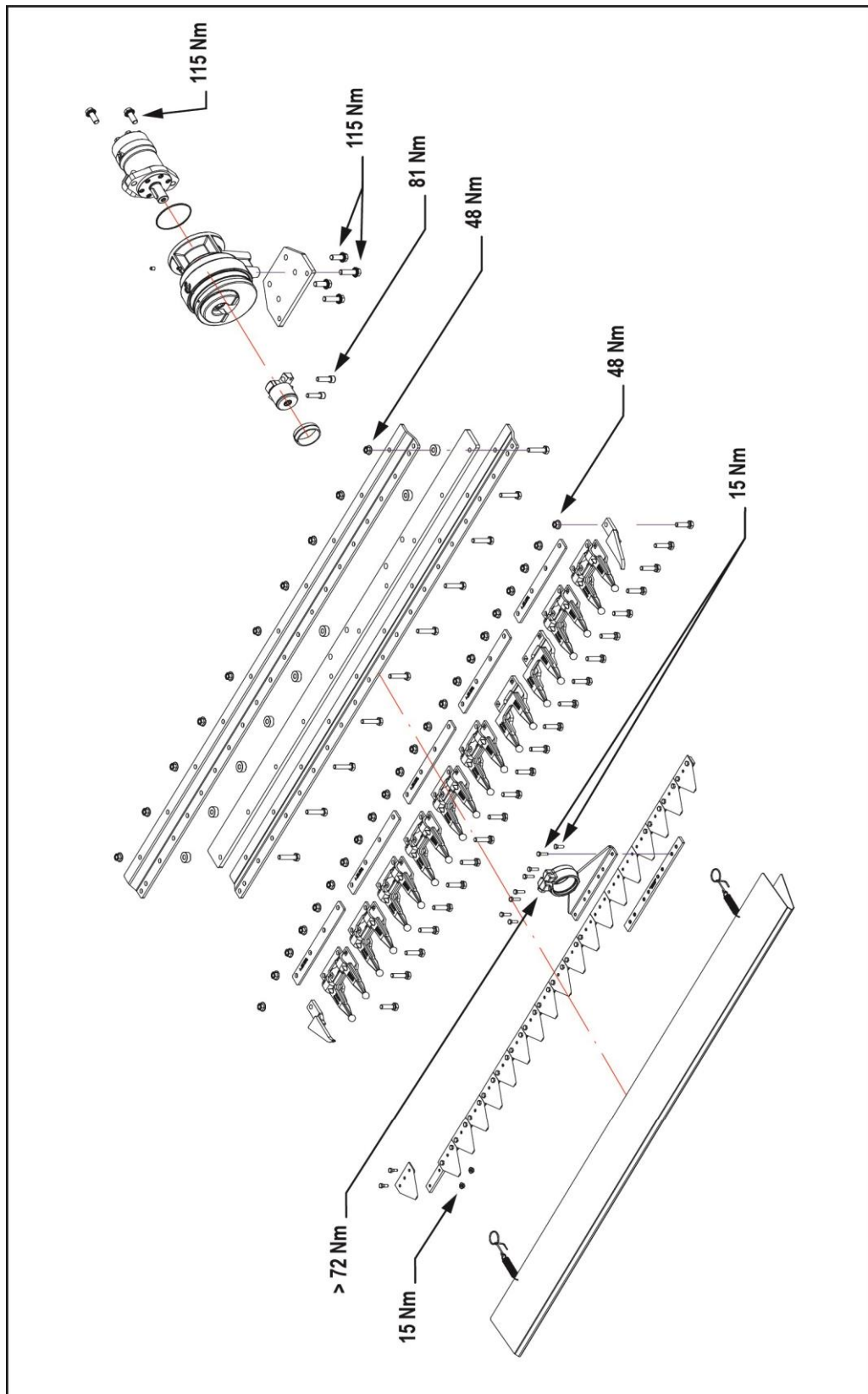



Merkurvej 25 | DK-6000 Kolding | Tel.: +45 75 55 36 44 | info@GreenTec.eu | www.GreenTec.eu

Cutting Edge Technology